



E-ISSN: 2347-2677
P-ISSN: 2394-0522
IJFBS 2018; 5(1): 148-151
Received: 24-11-2017
Accepted: 25-12-2017

Kamlesh Singh

Department of Farm Machinery
and Power Engineering, Indira
Gandhi Krishi Vishwavidyalaya,
Raipur, Chhattisgarh, India

Shambhu Singh

Department of Farm Machinery
and Power Engineering, Indira
Gandhi Krishi Vishwavidyalaya,
Raipur, Chhattisgarh, India

Gautam Verma

Department of Farm Soil and
Water Conservation Engineering,
Indira Gandhi Krishi
Vishwavidyalaya, Raipur,
Chhattisgarh, India

Short Note

**Evaluate the performance of multiple powered
knapsack sprayer in the field and laboratory**

Kamlesh Singh, Shambhu Singh and Gautam Verma

Abstract

The proposed device is design and developed for Chhattisgarh state, where the people of remote areas faces problems of electricity shortage, fatigue due to continuous operating to a manual knapsack sprayer is to need to purchase the fuel which increase the running cost of sprayer. In order to overcome these difficulties we have purposed a multiple powered knapsack sprayer of 16 liters capacity was developed using locally available materials and its performance evaluated. This device is developed to reduce the constant application of energy to throttle to regulate air pressure a problem in conventional knapsack sprayers. The major component include : tank, 12 volt electric water pump, 12 volt dry led battery, strap (belt), 10 watt solar panel, extention, 2 switches, rectifier, battery case, delivery pipe and a sprayer handle together with lance and nozzle. Electric water pump powered by 1 volt, 8 amperes hour battery (motorcycle type). Laboratory and field tests were conducted to determine floe rate, application rate and distribution rate. Basic hydraulic principle was considered for determining flow rate, while application rate was determined by effective use of walking speed on field. The result showed that the sprayer has a flow rate of 2.5 to 3 litres/min by using different nozzle, application rate of 1240 l/ha to 1485 l/ha. The result from the laboratory test indicated that the efficiency of spray decreased with decrease in voltage of battery and application rate is influence by walking speed. The sprayer capable of spraying 1240 l/ha to 1485 l/ha in 8.26 hours at a walking speed of 0.65 m/sec if solar panel is not connected then the device can't be operated continuously for more than 2.6 hours due to decrease in voltage. Battery can also be charged by solar panel. The 10W solar panel can produce 0.833Amp. The charging time of battery using solar panel has been measured by continuously charging battery and it is found that 11 hours for 2 days of everyday 8 hours.

Keywords: Knapsack sprayer, solar panel, application rate, charging time

1. Introduction

Farming the backbone of Indian economy, in this agriculture sector spraying is also an important operation to be performed by the farmer to protect the cultivated crops from insects, pests, funguses and diseases for which various insecticides, pesticides, fungicides and nutrients are sprayed on crops for protection. The growing concern to control plant diseases, insects and weeds for qualitative yield of agricultural products is increasing speedily in many developing countries like India. Crop spraying is employed for various varieties of purposes in traditional farming system. Traditionally, sprays were done by dipping broom, brushes or leaves into diluted (water added to chemicals) in a basin or any open container and sprinkling on the target area. Hand operated knapsack sprayer is the most prevalent type of knapsack sprayer in India which requires operators to continually move their hands in order to spray the liquid contained in the heavy knapsack. This easily causes fatigue on the operators back, shoulder and the muscles of the hand.

2. Materials and methods

2.1 Overview of the developed machine

The main functional parts of the machine include, the backpack tank, 12 volts battery, 12 volts battery operated water pump, a 12 volts solar panel (18 cm × 36 cm), Extension, 2 switches, rectifier, filter and sprayer handle with lance and nozzle. Backpack tank is a reservoir of spray mix with maximum capacity of 16 litres. The top opening with a cover is for filling and refilling of liquid. An outlet orifice constructed at the extreme bottom of the tank for discharge of liquid as shown in Fig. 1.

Correspondence

Kamlesh Singh

Department of Farm Machinery
and Power Engineering, Indira
Gandhi Krishi Vishwavidyalaya,
Raipur, Chhattisgarh, India

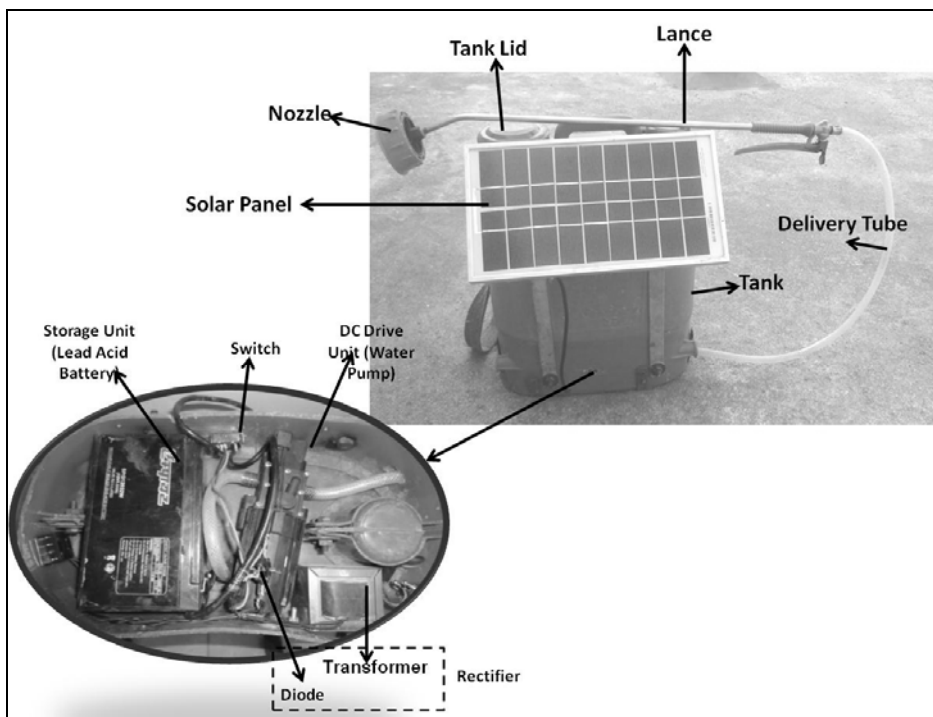

Fig 1: Developed Solar Operated Sprayer

2.2 Working principle of the developed sprayer

The block diagram of proposed system is as shown in Figure 2. It mainly consists of four units namely: energy conversion,

storage, DC drive and sprayer. The details of each unit are discussed as follows.

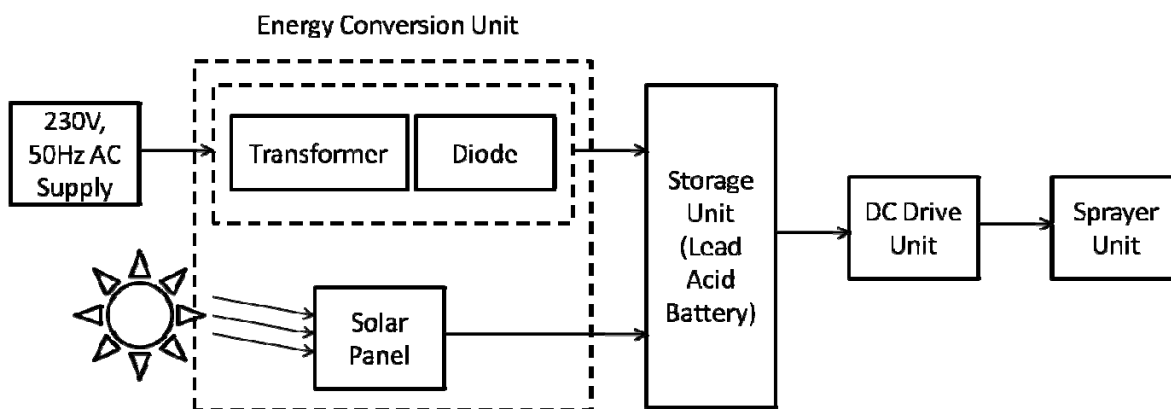

Fig 2: Block Diagram of the developed Solar Sprayer

The first unit of proposed system is energy conversion unit. The energy conversion can be done by two modes such as direct supply mode and solar energy mode. In case of direct supply mode, the single phase Alternating Current (A.C) supply was converted into Direct Current (D.C) supply with the help of full wave bridge rectifier which consist a step down transformer and diodes in star connection. 230 volts A.C. supply is converted into 12 volts A.C. and then diode converts it into D.C. supply. This can be used, wherever the solar energy is not available i.e. during rain and cloudy weather conditions. In case of solar energy mode, solar energy obtained by the sun is converted into electrical energy using solar panel by photovoltaic effect and stored in the battery.

The output of energy conversion was used to charge a deep cycle battery. The number of times a battery can be

discharged is known as its life cycle. For solar applications, a battery should be capable of being discharged in several times. In such cases a deep cycle battery is used. In this work a lead-acid accumulator serves the purpose. The lead-acid battery has the properties such as high current availability, contact voltage, longer life and more ability to charge as compare to conventional batteries.

The output of battery was connected to DC pump through a switch. In this work, DC pump is used because of the advantages such as less in noise, longer in life, maintenance free, motor speed can be varied in the larger extent by varying the supply voltage and self-lubricated. Pump is used to suck the spraying liquid from the sprayer tank and spray it through nozzle.

The sprayer consists of sprayer tank and sprayer pipe. The sprayer tank is made up of plastic or fibre material in order to

reduce the weight of the tank. The capacity of the tank is 16 litres and connected to the sprayer pipe with adjustable nozzle. By adjusting the nozzle the output of flow can be controlled. The whole unit can be carried conveniently at the back of human body with the help of shoulder straps. The

supporting base of entire unit needs to be strong and light weight.

The technical specifications of different components used for developing the solar sprayer was presented in table 1.

Table 1: Technical specifications of different components

S. No.	Particulars	Specifications
1.	Solar Panel (Polycrystalline)	Dimension: 180×360×25 mm
		Max power, P _{max} : 10W
		Voltage at Max power, V _{mp} : 16.8V
		Current at Max power, I _{mp} : 0.66A
		Open circuit voltage, Voc: 15V
		Short Circuit Current I _{sc} : 0.33A
		Tolerance: ±5%
2.	Rectifier (transformer + diode)	Transformer: step down transformer
		Diode: star connection
3.	Battery	Model no.: SPG12032W
		Capacity: 12V, 8Ah
		Output power: 96 watt
		Standby use: 13.6V -13.8V
		Cycle use: 14.1V-14.4V
		Max initial current: 1.4A
4.	DC Pump	Model no.: LF1524210
		Operating Voltage: 12V
		Operating Current: 3Amp (max)
		Flow rate: 2.5 to 4.5(max) litre/minute
		Weight of the motor: 800g (approx)
		Max. Fluid pressure: 40 psi or 2.81kg/cm ²

2.3 Performance evaluation of the developed sprayer

2.3.1 Determination of Flow Rate

A measuring cylinder together with a conical flask was used for accurate measurement of the volume of liquid discharged from the sprayer nozzle. A digital timer (stop watch) was used for recording the time of discharge. The procedure was repeated four times and the varying liquid heads were noted and the mean flow rate in liter per minute was calculated using the following formula.

Flow rate (L/min.) = Volume of liquid collected in cylinder (L)/Time (min.)

2.3.2 Determination of Application Rate

The 16 liter capacity of the sprayer tank was filled with liquid. The tank was mounted at the back. The electrical system was switched “ON” and the liquid was sprayed using the pressure of the pump. The effective performance of the developed sprayer was determined by practical trials in the field. The field test was made in an open field measuring 10 m by 10 m. The operator walked within a speed of 0.7 m/s through the test field. The discharged volume in liters per minute was recorded. This procedure was replicated four times and the mean value was determined.

2.3.3 Theoretical measurement of Current and Charging Time of battery

The current produced by the solar panel (I) was calculated by knowing the maximum power (P) of the solar panel and the voltage rating (V) of the battery.

Current = Maximum Power/Voltage rating

The theoretical Charging time (T) was computed by taking the ratio rating of battery in ampere hour (Ah) to the total current consumed by the solar panel.

Theoretical charging time = Rating of battery/Total current consumed.

2.3.4 Practical measurement of Current and Charging Time of battery

Experimentally the current produced by the solar panel was measured by connecting an ammeter in series with supply. The charging time of the battery using solar panel was measured by continuously charging battery.

3. Results and discussion

From the data recorded from the field and laboratory test, the average flow rate and average application rate of the developed solar sprayer was measured as 3 L/min. and 1285 L/ha, respectively.

The theoretical and practical parameters such as charging time, current, voltage and discharge time of the battery was presented in the table 2.

Table 2: Theoretical and practical data for different parameters

Parameters	Theoretical	Practical
Battery Charging time (hr)	9.6	11.2
Current (A)	0.833	0.5
Voltage (V)	15	14.25
Discharge time (hr)	-	2.66

4. Conclusion

The developed system would enhance the working capacity of farmer by reducing time and fatigue from continuous hand spraying. The current and time required for charging the full battery capacity of 12 V, 8 Ah by analytically and practically was found to be 9.6 h and 11.2 h, respectively. The fully charged battery could be used to spray 850 L to 1285 L of pesticides or fungicides, which approximately spray 2.5 to 3 acres of land. In this developed solar sprayer, there is a facility of charging the battery through electrical source which some time needed during spray operation in rainy days.

Discharge rate of the sprayer was found to be 3 L/min. but there is a chance of variation in the discharge capacity due to lack of constant walking speed of operator during field operation. Overall design of the developed solar operated knapsack sprayer puts weight of panel as well as sprayer on the shoulder of the operator, but it ultimately provides effortless operation.

5. References

1. Joshua R *et al.* Solar sprayer – an agricultural implement. International Journal of Sustainable Agriculture. 2010; 2(1):16-19.
2. Awulu JO, Sohotshan PY. Evaluation of a developed electrically operated knapsack sprayer. International Journal of Science and Technology. 2012; 2(11):769-772.
3. Rao VV *et al.* Multiple power supplied fertilizer sprayer. International Journal of Scientific and Research Publications. 2013; 3(8):1-5.
4. Khan Z. Unique solar operated spray jet. IOSR Journal of Mechanical and Civil Engineering. 2014, 43-46.
5. Patil AP *et al.* Performance evaluation of solar operated knapsack sprayer. Agricultural Engineering Today, 2014; 38(3):15-19.